

Basin Mixer

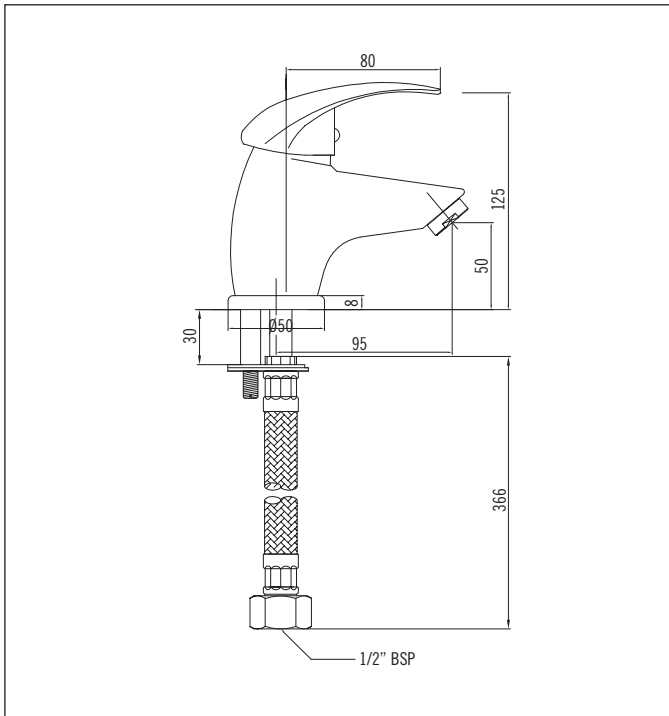

Code: RE BASM CP
 Finish: Chrome
 Spout: Fixed

Aerator supplied

Stainless Steel Inlet Hoses:

Hot:	I/D: 9mm
Size:	M16 x 1/2" BSP
Length:	400mm
Cold:	I/D: 6mm
Size:	M12 x 1/2" BSP
Length:	400mm

Metal Base Ring supplied with O-ring seal

Mounting Hardware:

Stud:	8mm
Nut:	11mm A/F
Horseshoe Washer	

Installation Hole Diameter:

Minimum:	32mm
Maximum:	42mm
Recommended:	34mm

Cartridge: Mondo 40k Plus Raised base

Equal pressure systems only

Recommended Pressure
 Operational Range:

Minimum:	50 kPa
Recommended:	600 kPa
Never to Exceed:	1000 kPa

Maximum Operating
 Temperature: 70°C

Aquatica Warranty

Aquatica NZ Limited offer, from the date of purchase, a 2 year warranty on handshowers, a 5 year warranty on tapware and accessories and a lifetime warranty on stainless steel sinks.

Aquatica NZ Limited warrants that only high quality workmanship and materials have been employed in the manufacture of its tapware, accessories and stainless steel products. If any faulty workmanship or materials is proven during the warranty period, Aquatica NZ Limited will at its own cost repair, or at its option replace, the faulty product. The guarantee is non-transferable and proof of purchase is required.

The use of spray or abrasive cleaners of any kind will void the warranty. (Tapware should only be cleaned with a mild detergent and a soft damp cloth).

Failure to use an in-line strainer or filter on lines to tapware incorporating a ceramic cartridge or ceramic disc mechanism will also void the warranty. In the Bay of Plenty (or any area with a high mineral content) failure to install a 1 micro carbon block cartridge may void the warranty.

Every effort has been made to show the products as they will be sold, however, all models and specifications are subject to change without notice.

Aquatica NZ Limited

9 Saunders Place, Avondale, Auckland.
 Tel: 09-828 2068, Fax: 09-828 2069
 Email: info@aquatica.co.nz or
 visit our website: www.aquatica.co.nz